

AIR FRYER

Comfee'

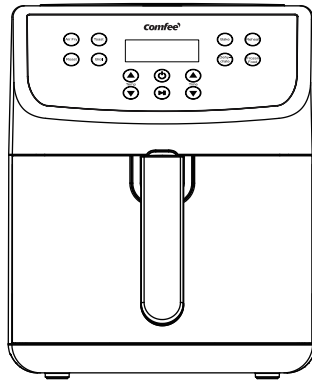

User Manual

Model: CFY55T6ABB



Please read the instructions carefully before use the machine
Please properly retention of the instructions for your future reference

IMPORTANT SAFEGUARDS

When using electrical appliances, basic safety precautions should always be followed including the following:

1. Read all instructions before using this Air Fryer.
2. Do not touch hot surfaces. Use handles or knobs.
3. To prevent electric shock or short-circuit, do not immerse cord, plugs, or appliance in water or other liquid.
4. This appliance is not intended for use by persons (including children) with reduced physical, sensory or mental capabilities, or lack of experience and knowledge, unless they have been given supervision or instruction concerning use of the appliance by a person responsible for their safety.
5. Unplug from outlet when not in use and before cleaning. Allow to cool before putting on or taking off parts.
6. Do not operate any appliance with a damaged cord or plug or after the appliance malfunctions or has been damaged in any manner. Return appliance to the nearest authorized service facility for examination, repair, or adjustment.
7. Only connect the appliance to a grounded wall socket. Always make sure that the plug is inserted into the wall socket properly.
8. This appliance is intended to be used indoors. Do not use outdoors.
9. Do not let cord hang over edge of table or counter, or touch hot surfaces.
10. Do not place on or near a hot gas or electric burner, or in a heated oven.
11. Extreme caution must be used when moving an appliance containing hot oil or other hot liquids.
12. Always attach plug to appliance first, then plug cord into the wall outlet. To disconnect, turn any control to "off", then remove plug from wall outlet.

IMPORTANT SAFEGUARDS

13. Do not use appliance for other than intended use.
14. Use extreme caution when removing tray or disposing of hot grease.
15. Do not clean with metal scouring pads. Pieces can break off the pad and touch electrical parts, creating a risk of electric shock.
16. Do not use for deep frying.
17. Avoid contacting moving parts.
18. Make sure the frying basket is locked into the front of the drawer - both frying basket handle tabs must be fully inserted into the notches on the top of the basket drawer.
19. Always make sure frying basket drawer is fully closed, with frying basket handle locked securely in the drawer, while Air Fryer is in operation.
20. This appliance has a polarized plug (one blade is wider than the other). To reduce the risk of electric shock, this plug is intended to fit into a polarized outlet only one way. If the plug does not fit fully into the outlet, reverse the plug. If it still does not fit, contact a qualified electrician. Do not attempt to modify the plug in any way.
 - a) A short power-supply cord should be used to reduce the risk resulting from becoming entangled in or tripping over a longer cord.
 - b) Do not use any accessories that have not been provided with the appliance.
21. **WARNING:** Air Fryer will not operate unless frying basket drawer is fully closed.
22. **CAUTION:** After hot air frying, the frying basket and frying basket drawer and the cooked foods are hot. Extreme caution must be used when handling the hot Air Fryer basket/drawer.

IMPORTANT SAFEGUARDS

23. **WARNING:** After air frying, make sure to place the frying basket drawer on a flat, heat-resistant surface before pressing the basket release button.

**HOUSEHOLD USE ONLY
SAVE THESE INSTRUCTIONS**

Parts and Features

1. Control Panel
2. Plastic Bottom Housing
3. Bottom Cover
4. Frying Basket
5. Drawer
6. Protective Button Cover
7. Basket Release Button

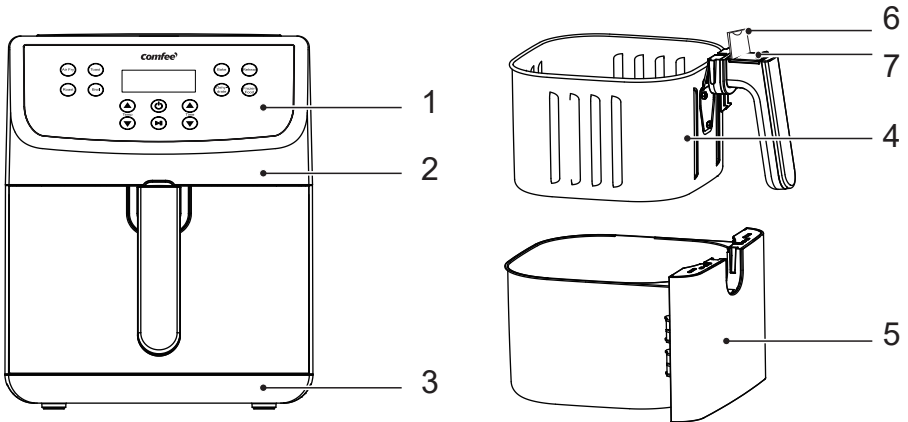

Technical specification

Model	Voltage frequency	Rated power	Rated Capacity
CFY55T6ABB	120V~ 60Hz	1700W	5.8Qt

Using Your Air Fryer

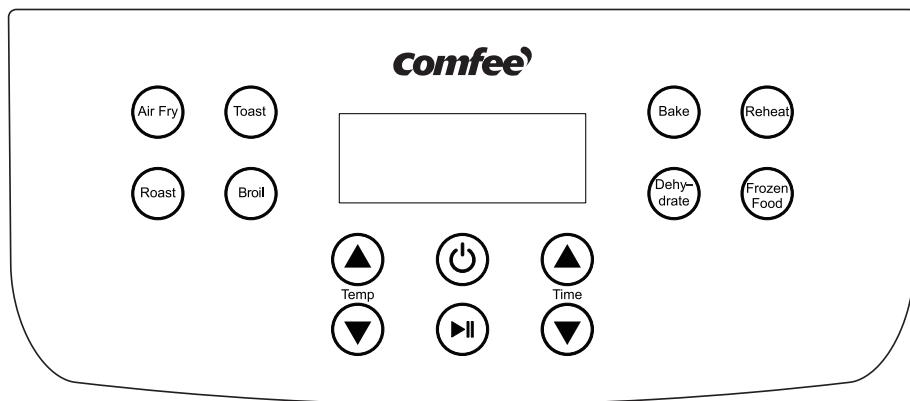

1. Insert the main plug into a earthed wall socket.
2. Press the power switch button.
3. Select the default menu or DIY setting of temperature/time.
4. Press Start/Stop button to start.
5. Press Start/Stop button to suspend the cooking process.

Note: Under the state of function selection, the selected state of default function, the working state and the state of work suspension, the machine may adjust temperature and time through the DIY setting function of temperature/-time. For the temperature adjustment, briefly press 5°F for run-out and long press it to rapidly adjust the temperature; For the time adjustment, briefly press 1 min for run-out and long press it to rapidly adjust time.

The default menu pre-sets the heating temperature and time:

Menu function	Temperature (°F(°C))		Time(MIN)		Shake Reminder?
	Pre-setting	Adjustment range	Pre-setting	Adjustment range	
DIY (Default Menu)	350(180)	170-400(80-200)	15	1-60	-
Air Fry (French Fries)	400(200)	170-400(80-200)	15	1-60	(SHAKE)
Roast (Root Vegetables)	400(200)	170-400(80-200)	40	1-60	(SHAKE)
Toast (Chicken Legs)	400(200)	170-400(80-200)	25	1-60	(SHAKE)
Broil (Shrimp)	400(200)	170-400(80-200)	10	1-60	(SHAKE)
Dehydrate (Beef)	120(52)	90-200(30-90)	10:00	1:00-24:00	-
Reheat	240(115)	170-400(80-200)	12	1-60	-
Bake (Cake)	360(180)	170-400(80-200)	15	1-60	-
Frozen Food (Chicken)	400(200)	170-400(80-200)	15	1-60	(SHAKE)

Preparation Work

1.The product should be steadily put on the desk (Fig. 1) . Make sure the power cord is long enough to plug in the socket (Fig. 2); the surrounding air of the product should be ventilated and it cannot get close to the flammable substance.

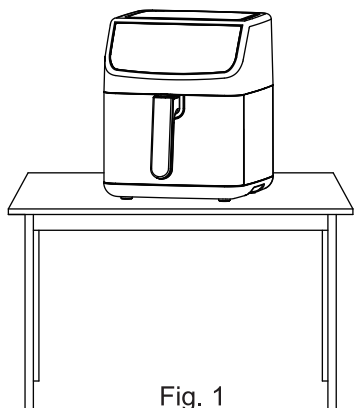

Fig. 1

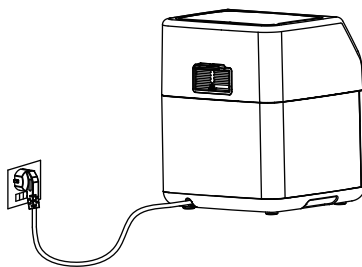

Fig. 2

2. Place the frying basket into the drawer, securing the basket in the drawer properly (Fig.3). Slide the drawer in the body of the unit (Fig.4).

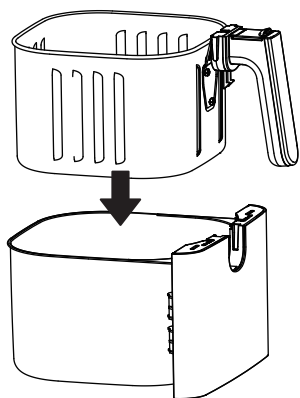

Fig. 3

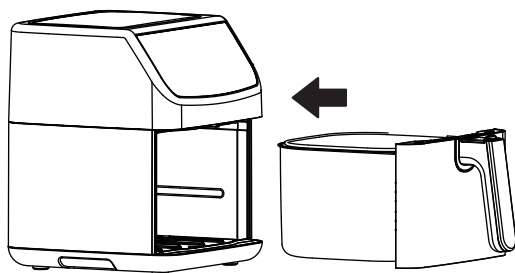
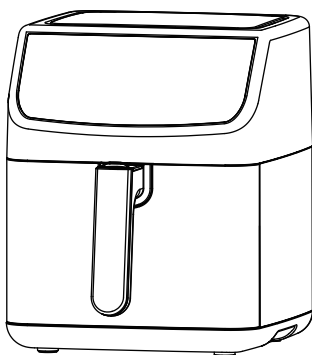

Fig. 4

3. Before putting the food content, preheat the machine for 3-6 minutes. Food will not cook thoroughly without preheating.



Usage

1. Press the top of the machine with one hand and pull the drawer out with the other hand. The drawer needs to be put on the desk.

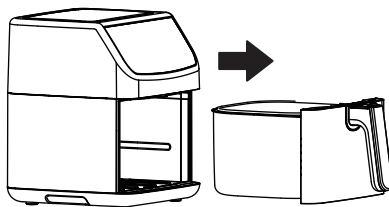

2. Put the food contents in the basket.

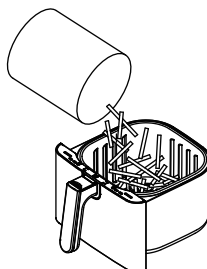

3. Put the drawer in the machine, after the machine is powered on, the machine beeps and touch the “⏻” button. Then the machine enters the working state and the interface shows the set temperature and time.

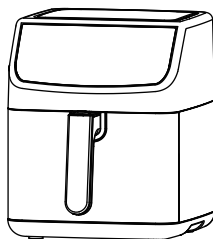

4. Select function through the control panel, the screen shows the set temperature and time or DIY through the control panel to set the according temperature and time, and then touch the start button. Then the machine enters the heating work state, cooks and heats the food content.

Note: When the drawer is not placed properly, the micro switch is not triggered; the machine is at the power-off state of getting the barrel and it won't work. At that time, you only need to totally push the drawer into the machine. The machine has the function of two-hour power off memory. After taking out the drawer and stirring the food in the process of food cooking, fully push the drawer into the machine and the machine restores the working state before the drawer is taken out, and continues to cook and heat the drawer.

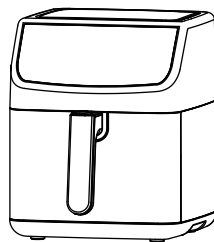

5. After reaching half of the set heating time, the machine beeps five times, “shake” light shows and pull out the drawer , flip sides of the food.

Shaking food

a) How to Shake

- 1) During cooking, take the baskets out of the air fryer and shake or flip the food. Be careful not to press the Basket Release Button.
- 2) When you take the baskets out, the air fryer will pause cooking automatically. As a safety feature, the display will turn off until baskets are replaced.
- 3) When you replace the baskets, cooking will automatically resume.
- 4) Avoid shaking longer than 30 seconds, as the air fryer may start to cool down.

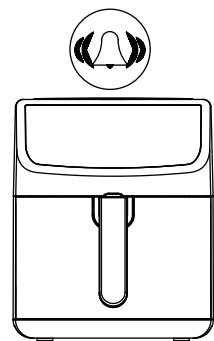

b) What to Shake

- 1) Small foods that are stacked will usually need shaking, such as fries.
- 2) Without shaking, foods may not be crispy or evenly cooked.
- 3) You can flip other foods, such as steak, to ensure even browning.

c) When to Shake

Shake once halfway through cooking, or more if desired Shake Reminder.

d) Shake Reminder

- 1) The Shake Reminder will alert you with 5 beeps, and “((SHAKE))” will blink on the display.
 - 2) If you do not remove the baskets, the Shake Reminder will beep again after 1 minute and the display will show a solid “((SHAKE))” after two times.
 - 3) The Shake Reminder will go away once you take out the baskets
-

6. The machine beeps after cooked, unplug the power plug. Unplug the socket, put it on the desk flatwise and take out the cooked food with the cooking utensils (such as chopsticks and clamp).

Please carefully take it out. Place the air fryer on a stable level, heat-resistant surface, so as to avoid being scalded by steam or toppling over the frying drawer, which may lead to scalding by oil or high temperature food. In addition, the cooking utensils (such as chopsticks) are suggested to be used in the process of taking out food.

Tips

- 1.Any discrepancy between the picture and the product is subject to the real object.
- 2.The altitude scope for the appliance to properly function is 0 ~2000 m.
- 3.For the first use, it should be heated dryly for ten minutes, during which process there may be a small amount of white smoke or unpleasant odor. It is a normal phenomenon and don't be panic-stricken.
- 4.Before the product works, please check whether the frying basket and the drawer are put in place, so as to avoid failure.
- 5.If the product is found to have any breakdown, please immediately stop using it and contact the service department of the company.
- 6.Please put both the frying basket and the drawer inside the complete machine for use, and avoid independent use.
- 7.DO NOT dispose of your Instruction Manual, keep for future use.

Cleaning and Maintenance

- 1.The appliance will be hot after using it. Wait for the appliance to cool down before cleaning it.
- 2.Clean the inside of the air fryer with a slightly moist, non-abrasive sponge or cloth. Do not immerse in water.
- 3.The baskets are dishwasher safe. You can also wash the baskets with hot, soapy water and a non-abrasive sponge. Soak if necessary.
- 4.Please wipe the air fryer with the soft and clean cloth. Please do not clean the air fryer with soaked cloth, so as to prevent water from entering inside the air fryer, which may easily lead to short circuit and fire.
- 5.Please do not clean the air fryer with other cleaning equipment like the dishwasher. Otherwise, it may lead to damage and effect the use.
- 6.Please clean the frying basket and the drawer with the neutral cleaning agent or clean water.

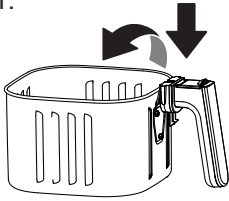

Uncover the "protection cover" and press the "key".

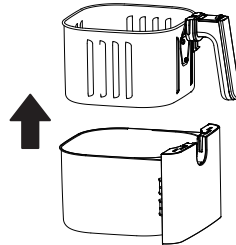

Just raise the "frying basket".

- 7.Do not clean the frying basket and the drawer with hard and sharp objects (such as the steel wool and blade), and avoid scratching the frying basket and the drawer.

Any other servicing should be performed by an authorized service representative.

TROUBLESHOOTING

SN	Problem	Cause	Troubleshooting Method
1	Not power on	Check whether the plug is plugged in place	Insert again or to another socket
2		The drawer is not assembled properly	Pull the drawer out and into the machine again to assemble properly
3		Thermostat (the protection device) is disconnected	Deliver the appliance to the authorized Maintenance Department
4		The display lamp burns out	After the power is on, if the motor works and heats up regularly, you can send the product to a designated maintenance service point
5	The motor doesn't work or has abnormal sound	There is foreign matter blocking the fan blade or steam inlet is blocked	After the power is off, check if there is foreign matter at the air inlet and inside the chamber; if there is still a fault, send the product to a designated maintenance service point
6	E01 alarm	NTC abnormal open circuit	Deliver the appliance to the authorized Maintenance Department
7	E02 alarm	NTC abnormal short circuit	Deliver the appliance to the authorized Maintenance Department

Name: Guangdong Midea Consumer Electric Manufacturing Co., Ltd.

Customer Service Management Office: 5 Sylvan Way, Suite 100 Parsippany, NJ, 07054

URL: <https://www.amazon.com/comfee>

Tel: 866-646-4332

E-mail: officialservice@comfeeappliance.com